

LEXINGTON®

HOME BRANDS

ASSEMBLY INSTRUCTIONS

790-953C End Table

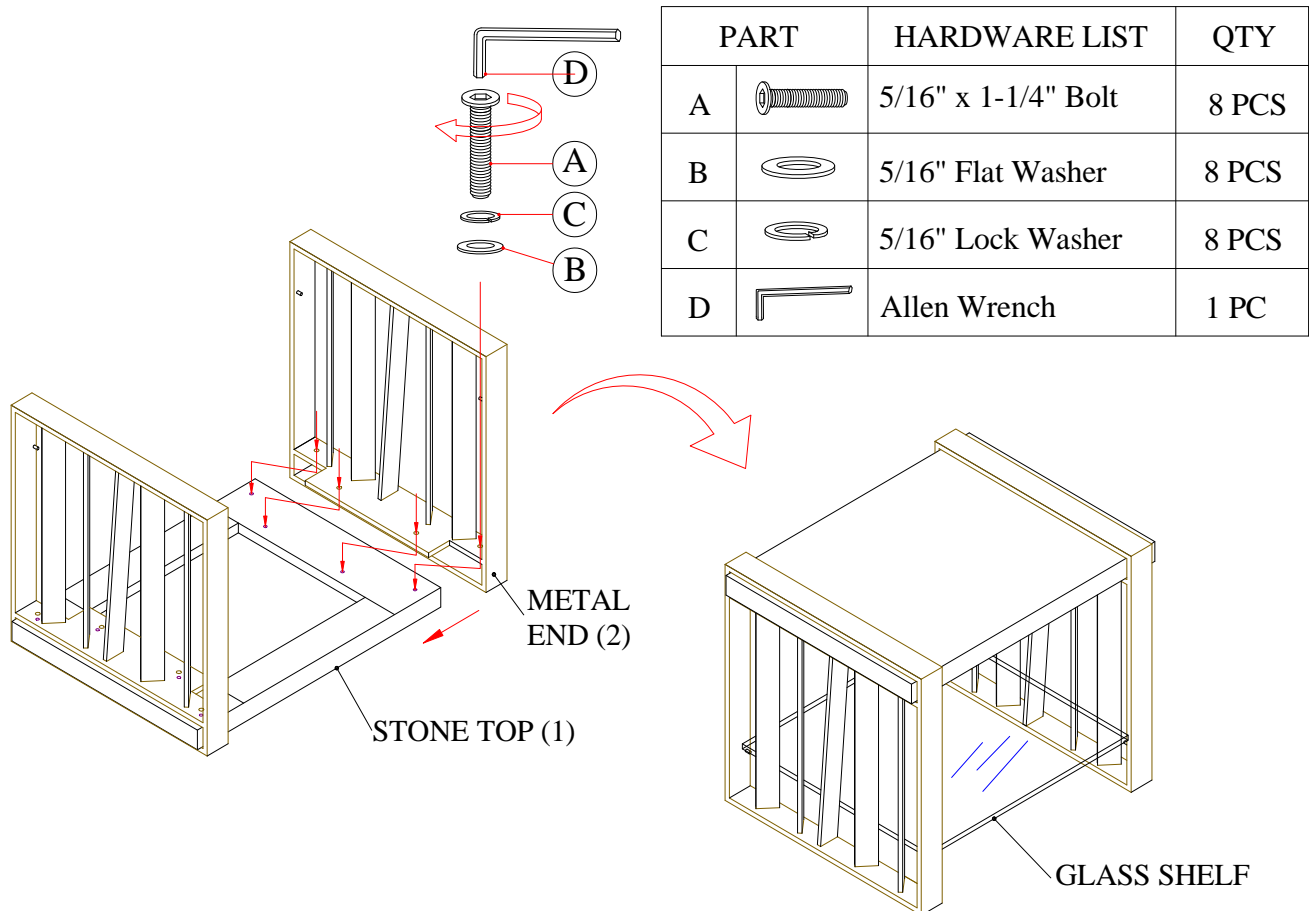

1. Place Stone Top upside-down on flat, clean, non-marring surface.
2. Slide one Metal End over end of Top so that holes on Metal End align with holes on Top.
3. Use Allen Wrench (D) to attach Metal End to Stone Top with (4) of each: Flat Washers (B), Lock Washers (C), and Bolts (A). Fully tighten all bolts.
4. Repeat steps 2-3 for other Metal End on other end of Stone Top.
5. Return assembled table to its upright position and place in desired location.
6. Carefully place Glass Shelf centered on rubber tipped shelf supports.

For additional consumer assistance please contact your Lexington dealer or call our Consumer Services Department at 1-336-474-5300, Monday-Friday, 8-5 Eastern.